

Challenger Fully Condensing Water Boiler and/or Water Heater



Engineering Submittal CC 125



- Low water content
- Limited 10 year heat exchanger warranty
- 1 year parts warranty
- Light weight construction for wall mounting
- Standard equipment:
 - ASME 30 psi [2 bar] pressure relief valve
 - pressure and temperature gauge
 - high limit temperature safety control
 - domestic lead free mixing valve
 - outdoor temperature reset control
 - air vent
 - 120 volt terminal strip (power supply and boiler primary pump)
 - pressure sensor low water cut off
 - variable speed blower
- Stainless steel premix knit burner
- Reliable spark ignition
- Attractive appliance design for installation in high visibility areas
- Use of 80/125 mm concentric vent and air for single wall penetration
 - Total vent and air pipe length up to 60 equivalent feet each. (Each 90° elbow = 10 ft, each 45° elbow = 5 ft)
- Use of 3" PVC, CPVC or AL29-4C® (available April 2011) pipe for vent and air
 - Total concentric vent and air pipe length up to 60 equivalent feet each. (Each 90° elbow = 5 ft, each 45° elbow = 3 feet)
- Minimum vent length: 5 equivalent feet and vent terminal

Engineering Submittal Data

- ASME Boiler Certification - ASME "H" Stamp
- Unit complies with ANSI Z21.13/CSA 4.9 Boiler and ANSI Z21.10.3/CSA 4.3 Water Heater Standards
- Fully condensing – 96% AFUE
- Microprocessor electronic gas and air modulation control
- Full modulation capability from 25% to rated input
- Modulation allows fewer and longer cycles leading to lower operating cost and longer component life
- Digital display control panel
- Electronic controls with easy to read menus, performance and trouble shooting codes
- Boiler water supply temperature can be maintained by the CHALLENGER, eliminating the need for a mix system to achieve the desired temperature with high limit protection
- Swing down control panel for easy access and service
- Control interface and logic for indirect fired hot water heater with priority
- Automatic boiler freeze protection
- Anti-freeze compatible per manufacturer's specifications
- Aluminum heat exchanger construction with vertical flueways with separate copper tube CH (Central Heating) and DHW (Domestic Hot Water) water ways

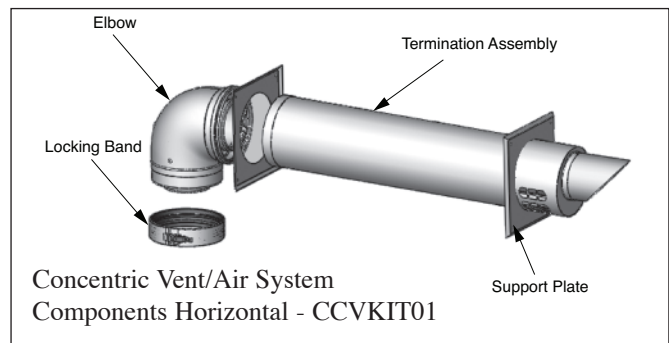

Project / Location: _____ Date: _____

Consulting Engineer / Architect: _____

Mechanical Contractor: _____

Notes: _____

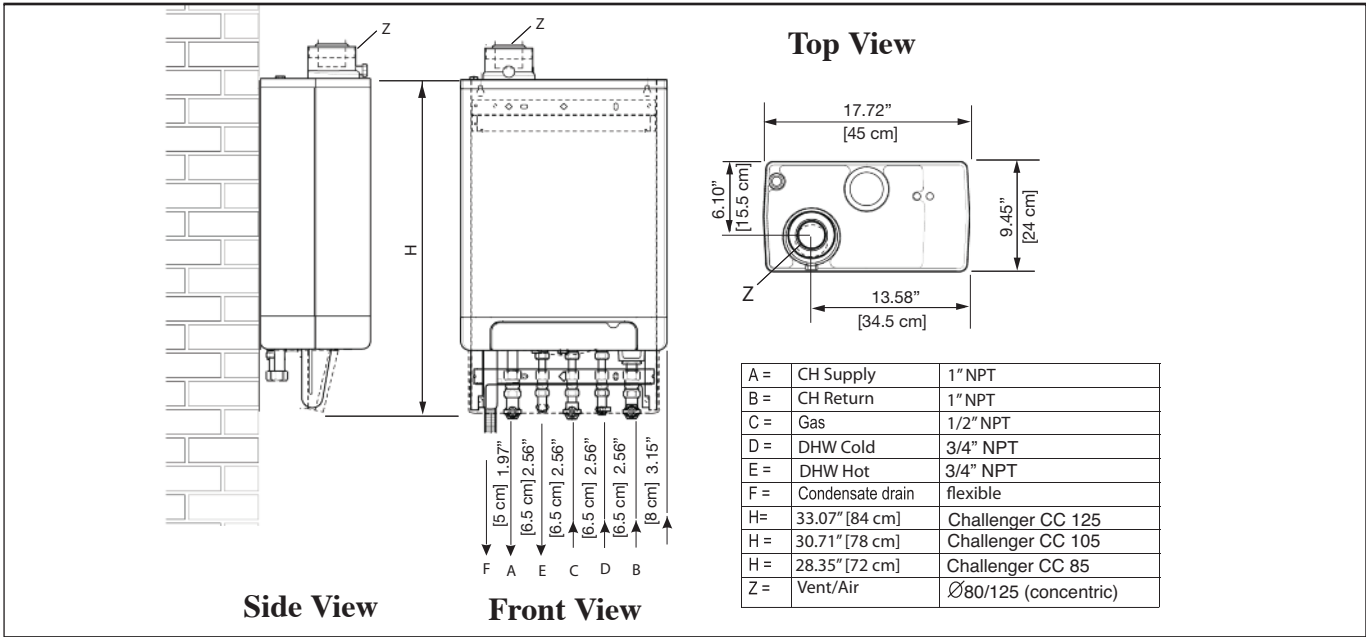

Model	Fuel	Input Modulation MBH [Kw]	AFUE	DOE Heating Capacity MBH [Kw]	Net I=B=R MBH [Kw]	CH Supply / Return Connections	Gas Connection	Air/Vent Diameter	Weight (Empty) [Kg]
CC 125	Natural or Propane Gas	33 to 124 [9.7 to 36.3]	96%	110 [32.8]	96 [28.4]	1"	1/2"	Concentric 80 mm Vent & 125 mm Air	80 [36]

CH Pressure Drop Curve

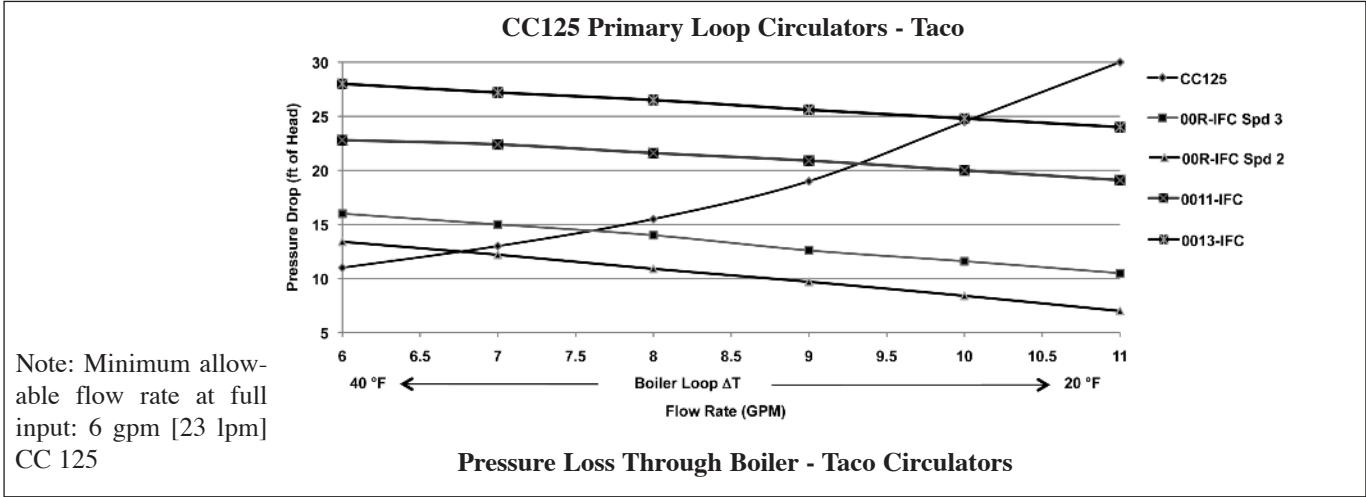
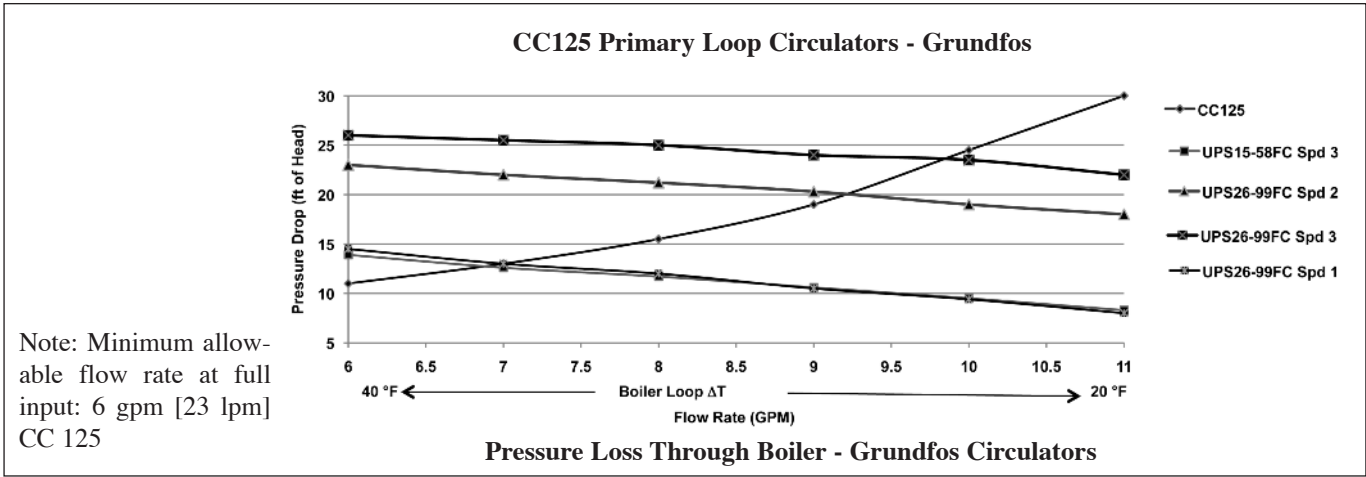

Model	Continuous Domestic Flow 70° F Rise	DHW Supply/Return Connections
CC 125	3.0 gpm [11.4 lpm]	3/4"

DHW Performance Curve

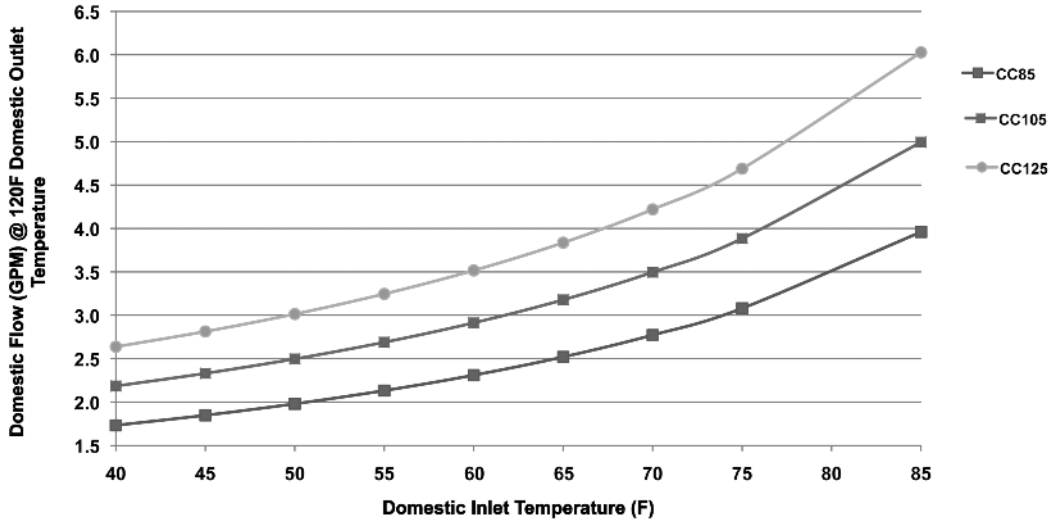

Domestic Flow Rate at 120°F Domestic Outlet and Varing Domestic Inlet Temperature

NOTICE

If actual flow rate exceeds the value listed in Graph the domestic outlet temperature will be reduced.

DHW Pressure Drop Curve

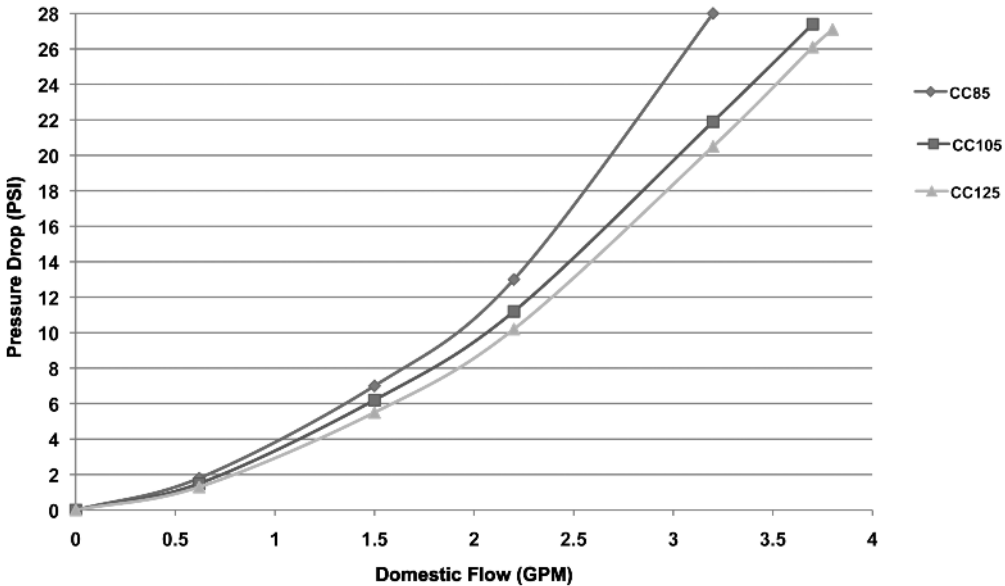

Pressure Loss Through Domestic